



Solar Box Cooker Construction Manual

By C.J. Colavito

July 2008



Table of Contents

| | |
|--|-----------|
| 1) INTRODUCTION | 2 |
| 2) TOOLS AND MATERIALS | 3 |
| A) PREPARATION OF THE WOOD | 4 |
| B) SHEET METAL AND PLYWOOD CUTTING GUIDES | 6 |
| 3) BASE FRAME | 8 |
| 4) COOKER FRAME | 10 |
| A) ATTACH THE COLUMNS TO THE BASE | 10 |
| B) ATTACH THE GLASS FRAME | 10 |
| C) ATTACH THE 3 CENTER COLUMNS | 13 |
| D) ATTACH THE FRONT RULE TO THE DOOR AREA. | 13 |
| E) ATTACH THE 5 INTERNAL BOX SUPPORT PEGS | 13 |
| F) PAINT THE FRAME | 14 |
| G) ATTACH THE SHEET METAL SIDES | 14 |
| 5) INTERNAL BOX | 16 |
| A) MAKE THE INTERNAL BOX OF FIBER BOARD | 16 |
| B) MAKE THE PRINTING PLATE LAMINATE FOR THE INTERNAL BOX | 17 |
| C) PAINT THE METAL SIDES OF THE COOKER | 20 |
| 6) REFLECTOR | 21 |
| A) ASSEMBLE THE REFLECTOR FRAME | 21 |
| B) ATTACH THE SHEET METAL FOR THE REFLECTOR | 21 |
| C) MAKE THE REFLECTOR LID | 21 |
| D) PAINT THE REFLECTOR | 22 |
| 7) DOOR | 23 |
| A) MEASURE THE CORRECT SIZE AND CUT OUT THE DOOR | 23 |
| B) MAKE THE INNER DOOR BOX | 23 |
| C) ATTACH THE DOOR HINGES | 26 |
| D) ATTACH THE DOOR TO THE COOKER | 26 |
| E) ATTACH THE SHEET METAL TO THE FRONT OF THE DOOR | 27 |
| F) PAINT THE DOOR | 27 |
| 8) BLACK COLLECTOR PLATE | 28 |
| 9) ASSEMBLY AND FINISHING | 30 |
| A) ATTACH THE DOOR LATCHES | 30 |
| B) ATTACH THE REFLECTOR TO THE COOKER | 31 |
| C) GLUE ALUMINUM FOIL TO THE REFLECTOR | 32 |
| D) DRILL AND ATTACH THE REFLECTOR PROP RODS | 32 |
| E) ATTACH THE MIRROR TO THE REFLECTOR | 33 |
| F) ATTACH THE DOOR HANDLE | 33 |
| G) MAKE THE DOOR SEAL | 34 |
| 10) CONDITIONING THE SOLAR COOKER | 35 |

1) **Introduction**

This manual was written for the Mujeres Solares de Totogalpa, El Centro Solar, and Grupo Fenix. It is intended to be a guide and a formal method of documentation of all the specific details which we have learned that make a better solar box cooker. My hope is that this manual will be shared, used, and improved upon within the global solar cooker community. The contents of this manual represent the sum of all the design improvements, process improvements, and general lessons learned during my year of volunteer work with Grupo Fenix. The ideas in this manual came from a number of sources, and primarily the knowledge of Nimia López, Marcio Pérez, and my year of experience in building and repairing solar cookers, and the solar cooker construction team (Alejandra Sánchez, Rumalda López, Reina López, and Elia Pérez). Of course none of this local knowledge would exist without the foundation of knowledge from the women of Unile, Nicaragua, and the global solar cooker community. I would like to specifically thank The Body Shop Foundation of the U.K. for funding the research and costs of producing this manual. I would also like to thank my wife Jenny for all her help with the slick document formatting.

Tools and Materials

2) Tools and Materials

Table 1: Materials

| <i>Description</i> | <i>Quantity</i> | <i>Unit of Measure</i> |
|--|-----------------|------------------------|
| Smooth zinc coated sheet metal (caliber 28) | 1.17 | sheet (144" x 36") |
| Pine wood | 17.5 | feet (12" x 12" x 1") |
| Glass | 2 | each (25.75" x 27.25") |
| Tube of silicon sealant | 2 | each |
| Latches (window sash type) | 2 | each |
| Marine blue oil-based paint | 0.17 | gallon |
| Plywood | 0.08 | sheet (8' x 4') |
| Fiber board | 0.33 | sheet (8' x 4') |
| Gypson coated 1" screws | 0.19 | box (500 screws) |
| Paint thinner | 0.13 | gallon |
| Black anticorrosive paint | 0.04 | gallon |
| White water based paint | 0.08 | gallon |
| White wood glue | 0.02 | gallon |
| Gypson coated 3" screws | 0.17 | box (144 screws) |
| Gypson coated 1/2" screws | 0.07 | box (500 screws) |
| Hinges (3 1/2") | 1 | set of two |
| Hinges (3") | 1 | set of two |
| Gypson coated 1 1/2" screws | 0.17 | box (144 screws) |
| Printing plate sheet metal | 3 | each |
| Door handle | 1 | each |
| Mirror (4" x 2") | 1 | each |
| Aluminum foil | 0.10 | roll of 75 sq. ft. |
| Nails, 3" | 0.29 | pound (68 nails) |
| Nails, 1" | 0.07 | pound (1400 nails) |

Table 2 – Tools

| | |
|---|--------------------------|
| Carpenter's pencil | Planer |
| Chisel | Pliers |
| Cordless drill | Rasp |
| Drill bits, 1/4", 1/8" and 3/8" | Rivet gun |
| File (for metal) | Safety glasses |
| Hammer | Silicon gun |
| Hand saw (with medium or large teeth, for cutting wood) | Small carpenter's square |
| Hand saw (with small teeth for cutting fiber board) | Tape measure |
| Large carpenter's square | Tin snips |
| Long straight edge | Utility knife |
| Paint brush, 2" | Work gloves |
| Phillips head screw driver #2 | |

Tools and Materials

a) Preparation of the Wood

The following dimensions of wood pieces are for a large solar cooker (30" x 30"). Start with 2.5 boards of pine wood, 7' x 2" x 6" (17.5 feet of wood). If there is no drawing referenced then the wood piece is simply a rectangular block of the dimensions given.

Please note that it is very important that all pieces are cut straight and square, especially the columns of the solar cooker or it will not fit together properly.

Table 3 – Wood Preparation

| <i>Description</i> | <i>Quantity</i> | <i>Length (in.)</i> | <i>Width (in.)</i> | <i>Thickness (in.)</i> | <i>Drawing Reference</i> |
|---------------------------------------|-----------------|---------------------|--------------------|------------------------|--------------------------|
| Reflector Frame | 4 | 31 | 2.5 | 1 | Drawing 1 |
| Base Frame | 4 | 30 | 2.5 | 1 | Drawing 2 |
| Center columns | 3 | 8 | 3 | 2 | Drawing 3 |
| Rear columns | 2 | 8 | 3.5 | 2 | Drawing 4 |
| Front columns | 2 | 8 | 2.5 | 2 | |
| Front rule | 1 | 26 | 1.5 | 0.75 | |
| Sides of the glass frame | 2 | 31 | 2.5 | 1.75 | Drawing 5 |
| Rear rule of the glass frame | 1 | 26 | 2.5 | 1.75 | Drawing 6 |
| Front of the glass frame | 1 | 31 | 1 | 1.75 | Drawing 7 |
| Reflector prop rods | 2 | 32 | 2 | 1 | Drawing 8 |
| Internal box support pegs | 5 | 2.5 | 1 | 1 | |
| Wood support block for door | 3 | 7 | 2 | 1 | Drawing 12, pg. 24 |
| Insulation blocks for collector plate | 5 | 2 | 2 | 0.5 | |

Drawing 1 – Reflector Frame

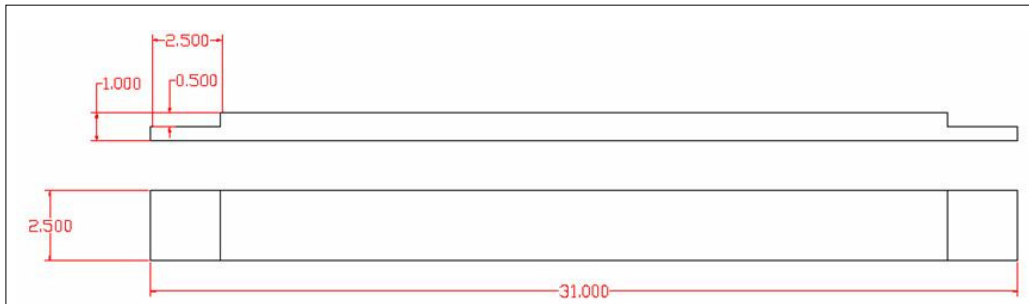

Drawing 2 – Base Frame

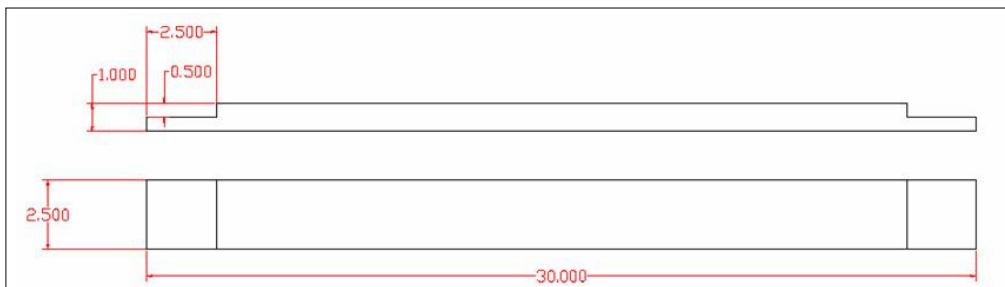

Tools and Materials

Drawing 3 – Center Columns

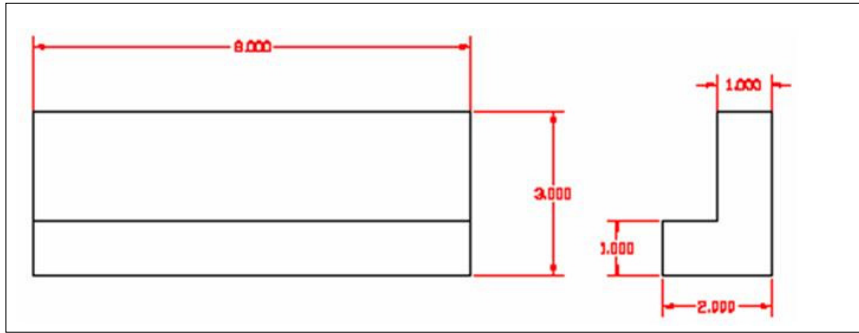

Drawing 4 – Rear Columns

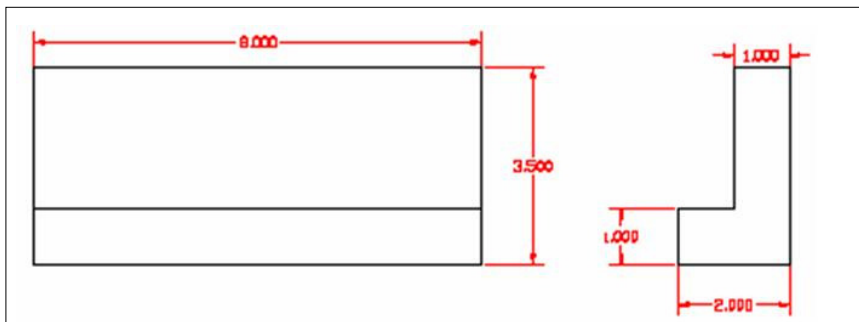

Drawing 5 – Side of the glass frame

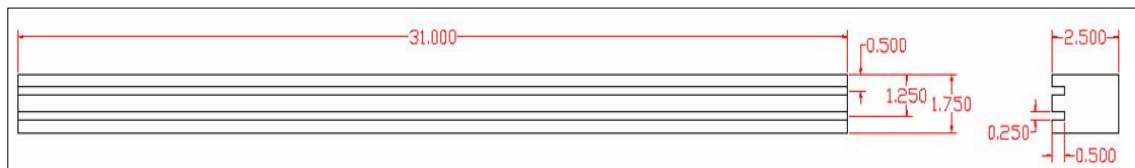

Drawing 6 – Back of the glass frame

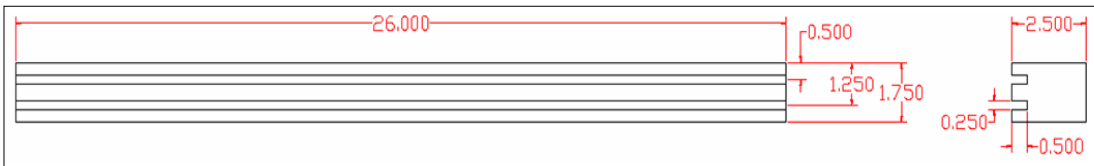

Drawing 7 – Front of the glass frame

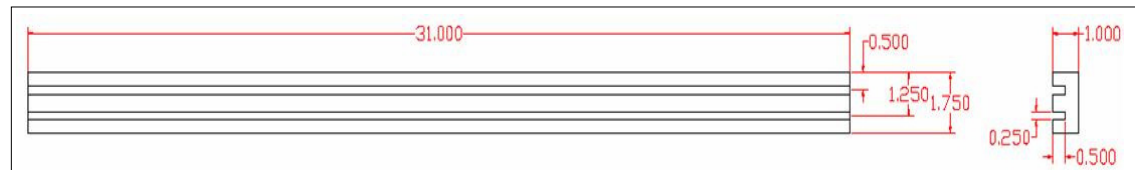

Drawing 8 – Reflector prop rods

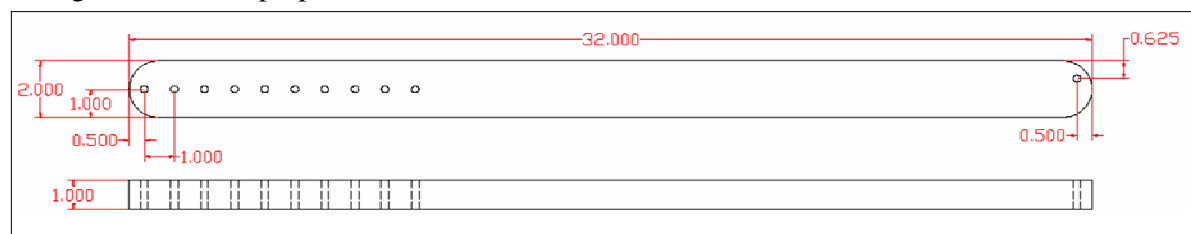

b) **Sheet Metal and Plywood Cutting Guides**

- i) **Sheet Metal:** In order to minimize scrap when cutting the sheet metal, use the following layout. As shown, the most efficient layout uses seven laminates to make six cookers.

Drawing 9 – Sheet Metal Layout

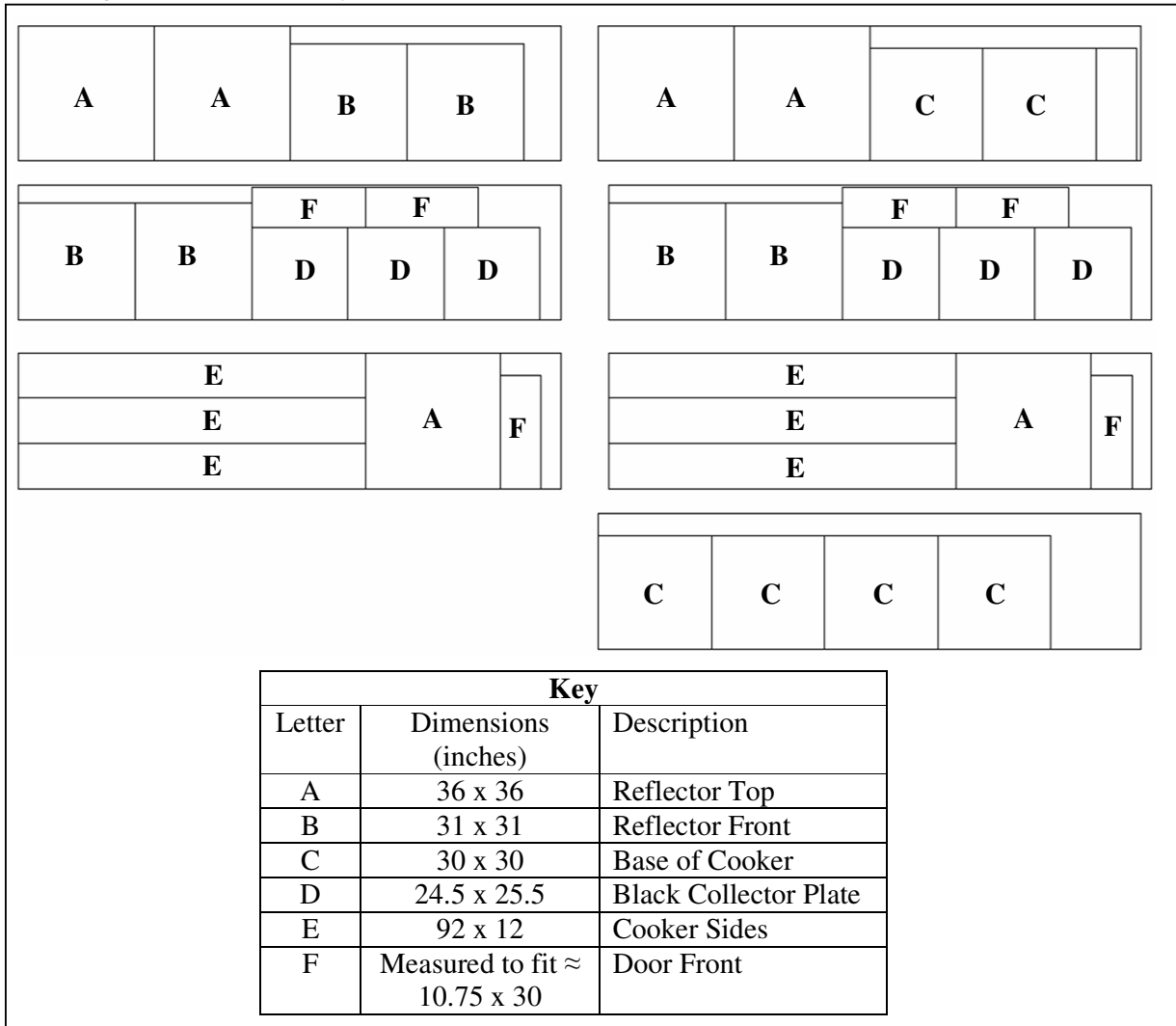

Tools and Materials

- ii) Plywood Layout: With one sheet of plywood you can make 12 doors, the layout below provides the most efficient use of wood and the simplest cutting.

Drawing 10 – Plywood Layout

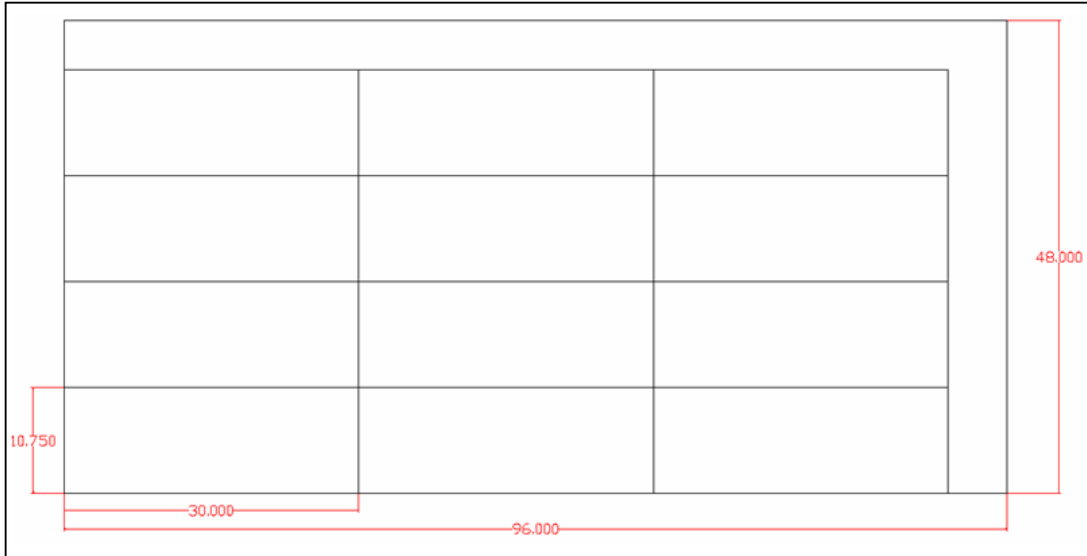

3) Base Frame

- a) Put the four 30" x 2 1/2" x 1" pieces into a square and put white glue in between each lap joint.
 - i) Use a carpenter's square to make sure that all the joints are square
 - ii) If it isn't square use a chisel to remove material until they fit properly
- b) Put five 1" nails in each corner of the frame; put them in a square pattern with one nail in the middle.

Figure 1

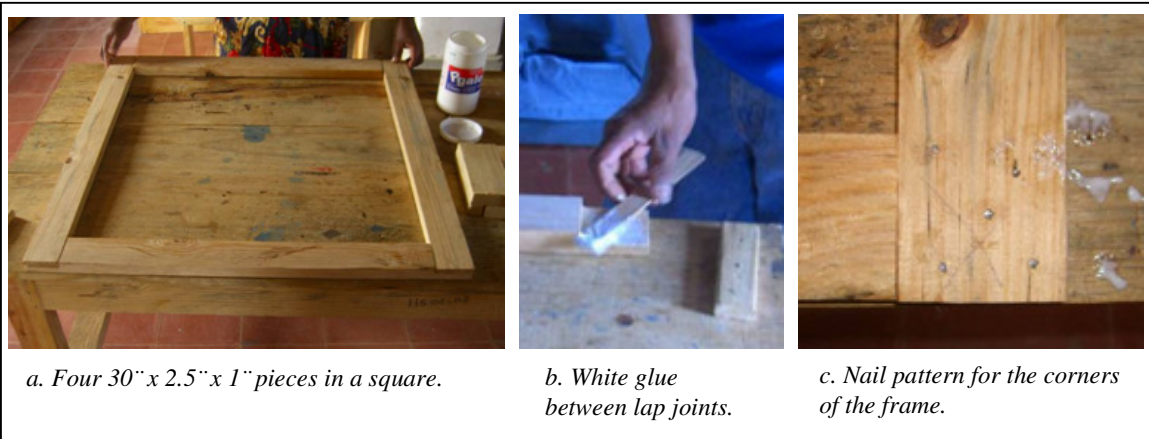

- c) **The pieces of the base frame need to be square and flat; if they are not flat you need to plane the wood to make it flat.**
 - i) Before using the planer first make sure that all the nails are deep into the wood so that the metal nails don't damage the blade of the planer.
 - ii) You can drive the nails in deeper using the head of a larger nail laid side ways over the head of the nail in the wood and hammering more.
 - iii) Flip the base frame over and bend the nail points that stick out over and hammer them flat so they won't poke through the metal that will be attached to this side.

Figure 2



- d) Cut a square of sheet metal 30" x 30"
- e) Lay the sheet metal on top of the base frame with the side that has the nail points facing up, lined up as good as you can with the frame.

Base Frame

- f) Nail down one corner of the sheet metal with a 1” nail to hold it in place. You may need to poke a hole in the sheet metal with a larger nail because the sheet metal is hard. Be sure not to make your puncture too big or the 1” nail will just pull through.
- g) Lift the sheet metal and put down a bead of silicon underneath to seal and bond it to the wood.

Figure 3



a. Lay a line of silicon under the metal.

b. Nail the sheet metal to the frame.

- h) Nail the sheet metal to the base frame using 1” nails that are 4” apart around the perimeter of the frame.
- i) Any parts of the sheet metal base that hang over the edges need to be hammered around the edge of the frame.

4) Cooker Frame

- a) Attach the columns to the base
 - i) Start with the 4 corner posts, two front, and 2 rear, the front ones should be rectangle shaped and the rear ones L shaped.
 - ii) **Verify that all 4 corner post have square, flat cuts on the ends by using a carpenter's square.**
 - (1) If an end of a column isn't square, use a rasp to level it out. It is important for the columns to be perfectly square or they will not mount to the frame correctly.
 - iii) Put on the two rear L shaped posts first by spreading glue onto one end.
 - iv) Place the base on top of the post with glue so that the side with the sheet metal faces up, using the other 3 in the corners to support the frame. The long part of the L shape should be flush with the back of the cooker.
 - v) **Make sure that the column is flush with the corner of the frame on both sides and that it is straight; also verify that the columns are 30" apart, measuring from the top of each column, not the base.**
 - vi) Make a hole in the sheet metal with a nail where you will put in a screw, then screw in a 3" screw to fix the column in place.
 - vii) Drive in a second 3" screw; use 2 screws in each column. Use the screw layout shown in figure 4c.
 - viii) Repeat for each of the 3 remaining columns.
 - (1) For the two front columns the side of the column that measures 2.5" should be facing forward.

Figure 4



- b) Attach the glass frame
 - i) Flip the base right side up so that the columns are on top
 - ii) Measure the distance between each column from outside edge to outside edge to make sure they are exactly 30" apart, if they aren't we will fix that as the glass frame is attached.
 - iii) Lay the front piece of the glass frame across the two columns of the front; make sure that the front edge is flush with the front edges of the two columns
 - iv) Mark the location of the inside edge of the front glass frame on the top of the two front columns, as shown in photo below. **It is important for the front of the cooker to be a flat plane surface so that you can make a good seal to it with the door.**

Cooker Frame

- v) Lay the two side pieces of the glass frame on the columns **with one end just behind the line for the front glass rule** and allow the other end of the side rule to extend past the rear column, as shown in the below photo.
- vi) Measure 30" between the front edge of the front column and rear end of the side glass rule and mark the 30" position on the side glass rule, as shown in the photo below. Determine if the frame needs to be compressed or stretched to reach exactly 30", if it is off by 1/8" or more you should adjust it.

Figure 5

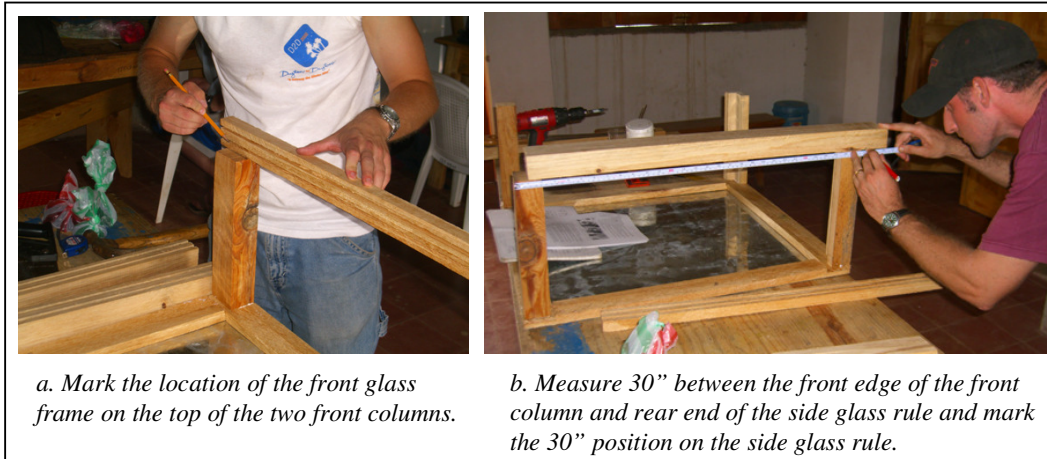

- vii) Cut the side glass frame piece exactly to the mark made. (it should be close to 29")
When attached to the rear column it should fit flush with the outside edge and rear edge of the column. The column may need to be stretched or compressed to make it fit right.
- viii) Spread glue on top of the front and rear columns where you will attach the first side glass rule.
- ix) Screw the side glass frame pieces to the columns
 - (1) Start by putting one screw in on the front side of the rule where the line on the front column is so that the front rule is secured in place, exactly on the line.
 - (a) Make a counter sink for the screw by drilling down 1/2" deep with a 3/8" drill bit.
 - (b) Drive in a 3" screw through the side rule and into the center of the front column. Make sure that the screw is not interfering with the glass channel.
 - (2) Drive 2 screws into the rear column.
 - (a) Make counter sinks for these screws as well using a 3/8" drill bit and drilling down by 1/2"
 - (b) For the rear side of the frame stretch or compress the column of the frame to be flush with the end of the rule
 - (c) Drive in the two screws while holding the column in the desired location; this will take at least two people to do.
- x) Attach the rear glass frame piece
 - (1) Measure the distance from outside edge to outside edge of the two rear columns, it should be exactly 30", if not you will need to stretch or compress your frame to make it exactly 30".
 - (2) Lay the rear glass frame piece across the two rear columns and determine the length needed to meet exactly 30" and mark and cut the rule. (it should be about 25")

Cooker Frame

- (3) Test fit the rear glass frame piece by laying it across the two rear columns. Use a carpenter's square to verify that the two rear corners of the glass frame are square. **It is important that they are at least close to 90° angles so that the glass fits correctly.**

Figure 6

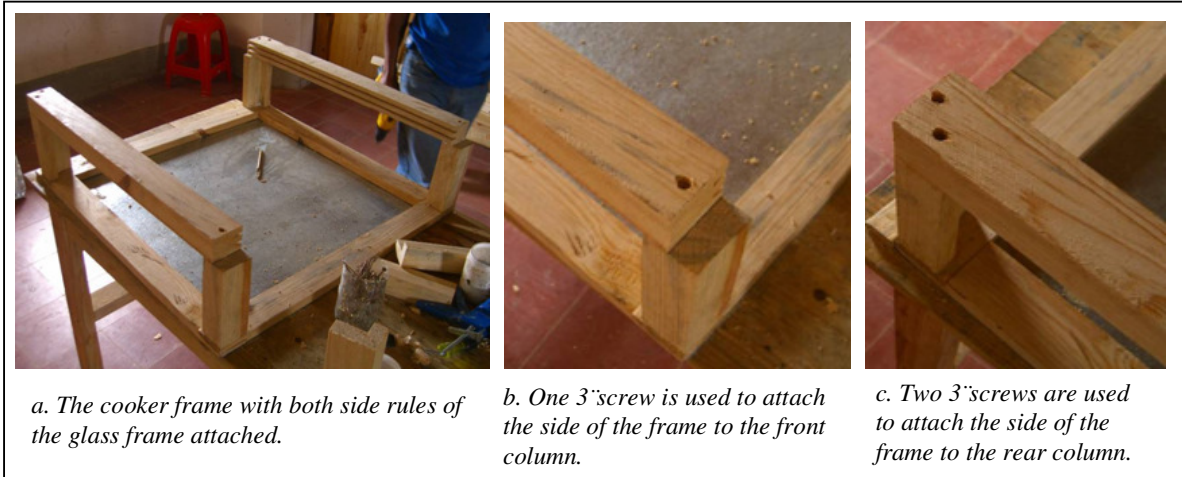

- (4) Remove the rear glass frame piece and spread glue over the area of the two rear columns that are exposed
- (5) Lay the rear glass piece across the two columns
- (6) **Verify that the channels are lined up correctly in both corners.** It is very important for the channels to line up properly or the glass won't fit.
- (7) Make a counter sink on each side for the screws, use a 3/8" drill bit and drill down 1/2"
- (8) Put one 3" screw in on one end of the rule; drive the screw in at an angle so that it is sure to hit the column beneath, which is at the very end.

Figure 7



- (9) Stretch or compress the frame to make the columns 30" apart from outside edge to outside edge while putting in a screw on the other end of the rear glass rule. You will need at least 2 people to do this step.
- (10) Check the alignment of the glass channels in each corner again, Test the fit with one of the sheets of glass by carefully sliding it into the channels from the front of the cooker. If it can't go in all the way, don't force it; remove the

Cooker Frame

interfering wood with a chisel, sand paper or file until it fits. Test both the top and the bottom channels. It is best to use gloves when handling the glass because the edges can cut your hands easily.

- c) Attach the 3 center columns
 - i) Measure and mark the center of each side of the cooker frame.
 - ii) Spread glue over the top and bottom of each of the 3 remaining columns.
 - iii) Set them into place in the center of each side, leaving the front open for the door
 - (1) The long side of the L shape should be flush with the outside edge of the cooker.
 - iv) Hammer two 3" nails in through the top of each column.
 - v) Flip the whole frame over and drive two 3" screws into the bottom of each column.

Figure 8



Figure 9

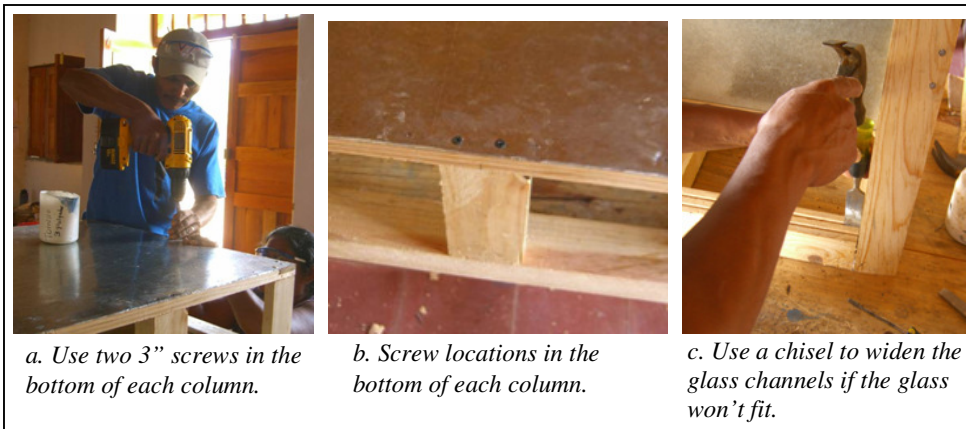

- d) Attach the front rule to the door area.
 - i) Spread glue across the sides and bottom of the front door rule and place the front rule (25" x 1.5" x 3/4") in the bottom of the door opening. The 1.5" side of the rule should face out.
 - ii) Nail it in with three 2" nails, equally spaced.
- e) Attach the 5 internal box support pegs.
 - i) Cut 5 small pieces of wood to 1" x 1" x 2.5"
 - ii) Mark the locations where the pegs will be placed from the inside of the cooker frame. Mark the center, and 7" in towards the center from each corner.
 - iii) Punch small holes in each location with a nail
 - iv) Flip the frame over

Cooker Frame

- v) Place a dot of silicon on each peg and place the peg up underneath, on the inside of the cooker. Nail the peg in with a 1" nail. In order to nail in the peg you will need to place a block of wood under it that extends down to the table. (See figure 10b)

Figure 10

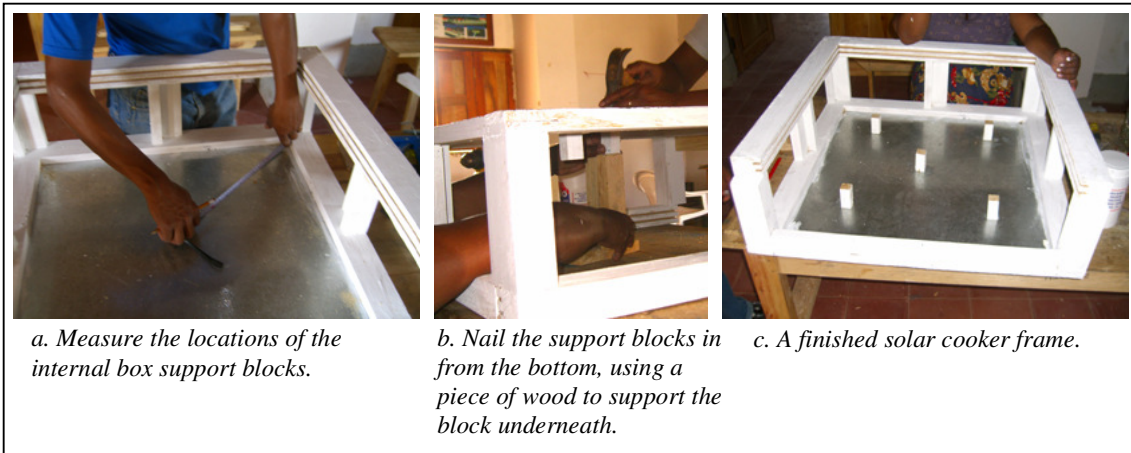

- f) Paint the frame
 - i) Paint the entire frame with white water based paint
 - ii) **Be careful when painting the area where the glass channels are; too much paint can gunk up the channels and prevent the glass from sliding in.**
 - iii) Don't paint any of the metal
- g) Attach the sheet metal sides
 - i) Cut a piece of sheet metal to 92" x 12"
 - ii) Mark and bend over each long side by 1/2"; Bend over the sides completely so that there is no sharp edge.
 - (1) Lay the sheet metal on a work table and line up one of the marks with the straight edge of the table
 - (2) Bend the sheet metal over the edge of the table using a hammer, use the edge of the table as a guide, starting at one end and working your way across the sheet metal.
 - (3) Flip the sheet metal over and carefully use your hands (with gloves!) to fold it over further. If it is too hard to do with your hands start it off at one edge with the hammer.
 - (4) Use a hammer to finish flattening the fold down. Be careful not to hammer too much because the metal may break.

Figure 11

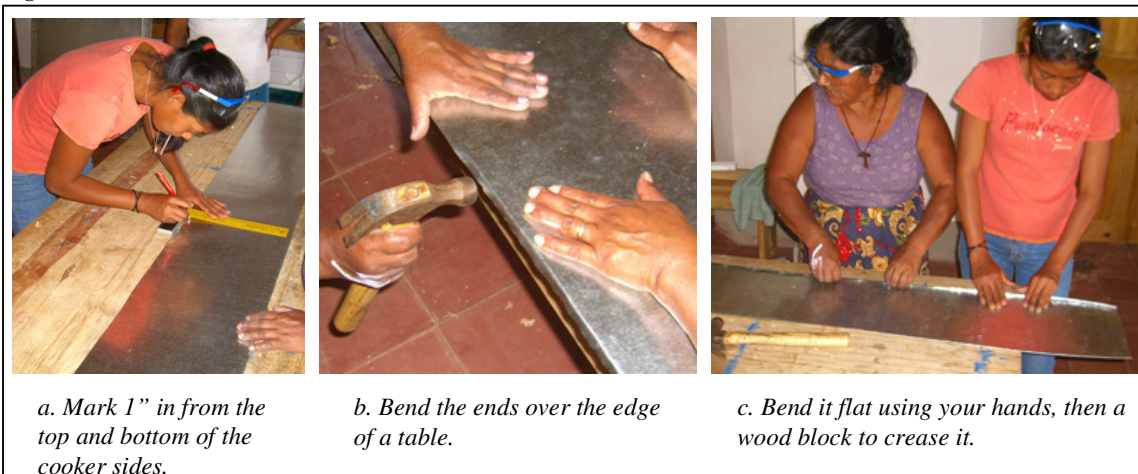

Cooker Frame

- iii) Screw the sheet metal sides onto the cooker frame.
- (1) Upend the cooker so that it is sitting on one if its sides with the door facing to the left or right.
 - (2) Lay the sheet metal on side of the cooker and **line up the top side of the sheet metal so that it is flush with the top of the cooker**. If there is a little over hang on the bottom it can be bent over with a hammer later.
 - (3) Begin with three 1” screws down one side taking special care that it is extremely straight and square, a slight angle will result in the metal being way off on the opposite side. **It is important that the sheet metal remains flush with the top of the cooker.**
 - (4) Lift the sheet metal up and place a bead of silicon around the perimeter of the frame beneath to seal the metal to the wood frame.
 - (5) Finish screwing in the sheet metal sides, use 1” screws 4” apart and one screw in the center of each column. You should use a hammer and a nail to puncture the sheet metal at each screw location.
 - (6) Work your way around the perimeter of the frame, always avoiding bubbles in the metal by pressing it flat and working your way from one end to the other; NOT from both sides and meeting in the middle. Make sure it is straight and flush with the top edge of the cooker.
 - (7) When the opposite end is reached, stop a couple screws early and cut the excess sheet metal that extends past the front of the cooker so that it is even or slightly behind the front of the cooker. Finish putting in the last screws afterwards. This allows you more space to cut the front edge easier and make sure it is flat with the front of the cooker.
 - (8) Use a file to smooth the rough edge left from the tin snips if necessary.
- iv) Bend any overhanging sheet metal over the bottom edge of the cooker using a hammer. At each of the two corners, a small cut in the sheet metal is necessary to allow it to fold flat.

Figure 12



5) Internal Box

- a) Make the internal box of fiber board
 - i) Begin with the two sides by measuring the distance from metal of the base of the cooker to half way up to the first channel in the glass frame. Also measure the distance from the inside edge of the rear glass frame to ½” overlap on the front column (your measurement should be about 26” x 8 ¼”)
 - ii) Cut a piece of fiber board to match the dimensions taken for each side
 - iii) Test fit the fiber board in place and cut notches out of necessary corners to make it fit.
 - iv) With the cooker laid on its side, fill the side with insulation, you can use wood curls or saw dust
 - v) Place of bead of silicon across the top, front and bottom where the fiber board will rest
 - vi) Lay the fiber board over the insulation and nail it in at the top, front and bottom using 1” nails 3 inches apart. **Be careful when driving in the nails that they go in straight and don’t cut into the glass channel.** Also make sure that the nails are going into the wood beneath.
 - vii) To form the back of the internal box, use the same height as measured for the two sides and measure the distance between the two fiber board pieces attached to the sides as the length.
 - viii) Cut the fiberboard piece, fill the space with insulation, place a bead of silicon on only the top and bottom, and then nail in the fiberboard with 1” nails three inches apart.

Figure 13

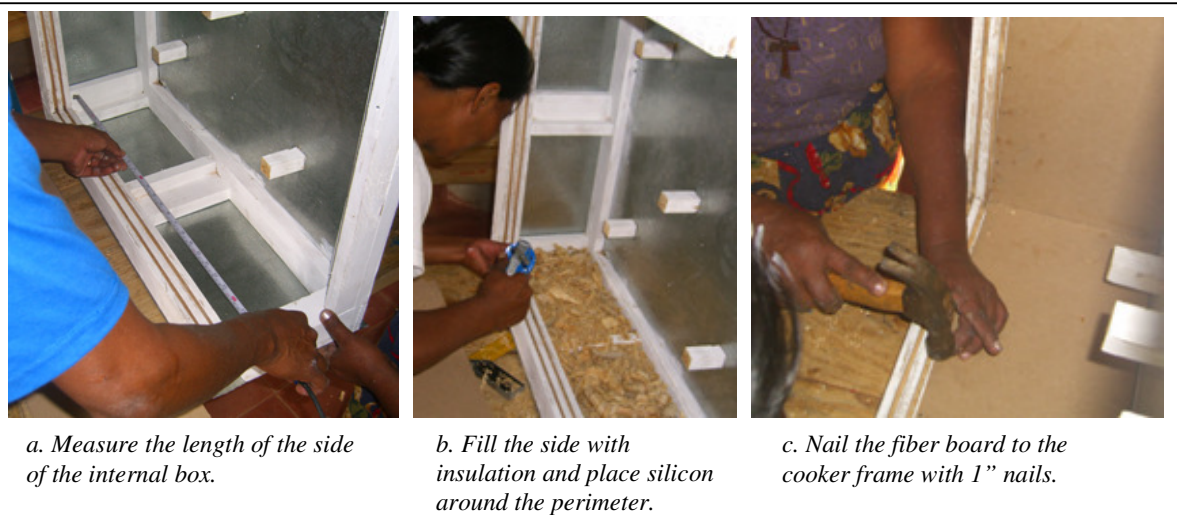

- ix) To form the base of the internal box measure the width between the two internal box sides at both the front and the back of the box. Also measure from the back wall of the box to the inside edge of the front rule at the bottom of the door opening.
 - (1) The base must fit inside the front rule, not overlap with it.
- x) Cut the base out of fiber board and test fit it.
- xi) Remove the fiber board base and place a dab of white glue on the center of each of the 5 support pegs.
- xii) Place the base back in to the cooker and press it down to get the glue to make a mark on the fiber board.

Internal Box

- xiii) Remove the fiber board and turn it over to see the glue dots.
- xiv) Puncture a hole in the center of each glue mark with a 1" nail.
 - (1) These holes will indicate where you will place your nails to attach the internal box base to the cooker.
- xv) Fill the space in the base of the cooker with insulation
- xvi) Place the fiber board base back into the cooker and press it down
- xvii) Hammer one 1" nail into the base at each hole location; 5 nails in total.
- xviii) Place a small bead of silicon around the perimeter of the base of the internal box and at each seam in the corners to seal the box.

Figure 14



- b) Make the printing plate laminate for the internal box.
 - i) Remove the bent over ends of two 30" x 23.5" printing plates by bending them back and forth until they fall off.
 - ii) Wash the printing plates to remove any remaining ink and make them shiny. Don't scrub them or use a rough sponge to clean it because it will scratch the surface making it less reflective.
 - iii) Measure and mark 1" in from one of the 30" edges along the entire edge of the shiny side of one printing plate
 - iv) Repeat for the second sheet, but mark it on the dull side of the printing plate
 - v) Use a straight edge and gently fold up along each line, but don't crease the fold
 - vi) Fit the two sheets together so that the 1" folded tabs are interlocking with the shiny sides of both facing upward. (see Figure 15)

Figure 15

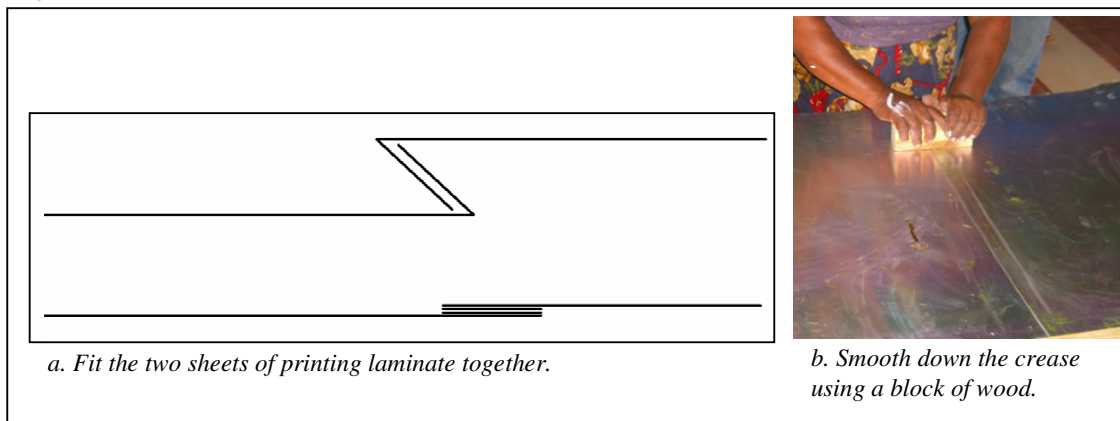

Internal Box

- vii) Crease the folds, locking the two sheets together; you can rub a block of wood over the fold to crease it well and flatten it down.
- viii) Make 3 holes in the center union of the two sheets using a 3" nail; one hole in the middle, and one hole 4" in from each end.
- ix) Use a rivet gun and pop rivets to fasten the sheets together at each of the 3 holes.
- x) Measure the length (depth) of the internal box **plus 1/2" overlap on the front rule**. (it should be about 26.5")
- xi) Measure and mark this distance on the printing plates according to Drawing 11.
- xii) Measure the width of the internal box. Subtract 1/4" and mark this width centered on the printing plates.
- xiii) Measure the height of the walls of the internal box. Subtract 1/8" and mark it on the printing plate by measuring out from each of the two lines for the width.
- xiv) Use a utility knife and a straight edge to score along the lines for the tops of the walls, and then bend the metal back and forth until it breaks to remove the excess metal.
- xv) Cut along the lines for the widths of the base starting at the back moving forward only until you reach the line for the depth of the base. **Don't cut all the way!** (your cuts should be about 3" deep)

Drawing 11 – Laminate Layout

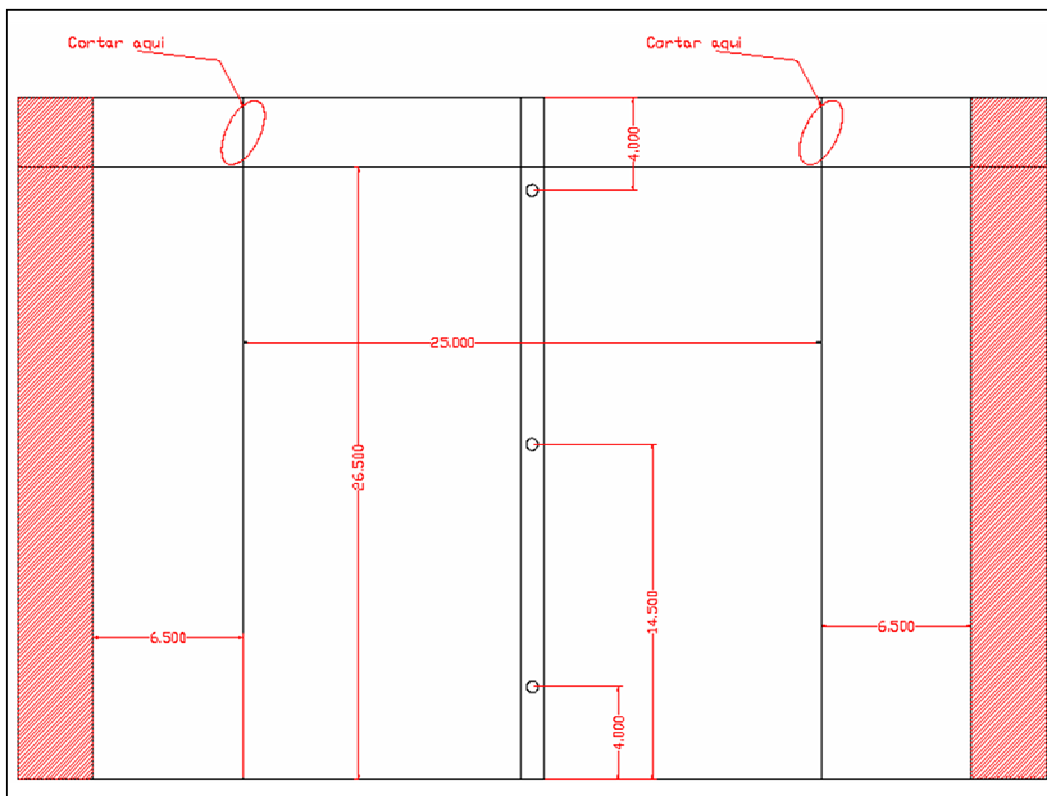

- xvi) Fold up the back and side walls to be at a 90° angle with the base. Use a large carpenter's square or straight edge to help fold it straight.
- xvii) Fold in the rear corners to form the back wall of the internal box.
- xviii) Test fit the printing plate box inside the internal box.
- xix) If the walls extend over the lower glass channel at all, then they must be cut
- xx) Verify that the depth of the printing plate box is also correct; it should overlap the front rule by 1/2", not sticking out of the front of the cooker.

Internal Box

- xxi) Remove the metal box and put a bead of silicon around the perimeter of the top of the internal box and the front of the door opening. Don't put any silicon on the back wall of the internal box.
- xxii) Place the metal box into the cooker and press it into place.

Figure 16

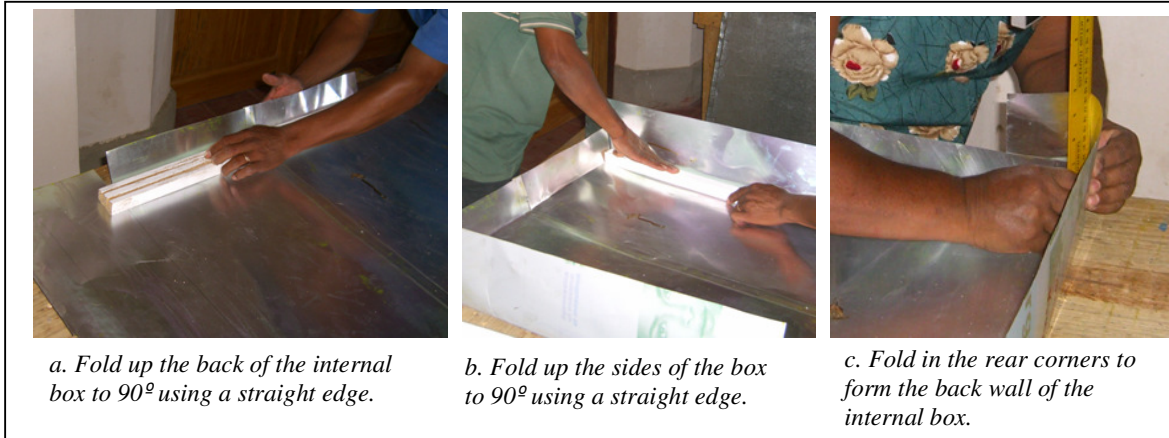

- xxiii) Use 1" nails to nail the metal box to the internal box.
 - (1) **Verify that the metal box is flat and pressed all the way back and down in the internal box so it fits into the corners. This is especially important at the door opening, if the metal isn't tight into the corners it will interfere with the door insulation box.**
 - (2) **Start by nailing the front down to the bottom of the door opening, then up the side columns of the door opening.** This will ensure that the laminate is pressed flat at the bottom and is tight in the front corners of the cooker.
 - (3) Only nail around the perimeter of the top and the opening of the door where there is wood beneath. The fiber board will not hold a nail on its own.
 - (4) Again, make sure none of the nails protrude into the glass channel.

Figure 17

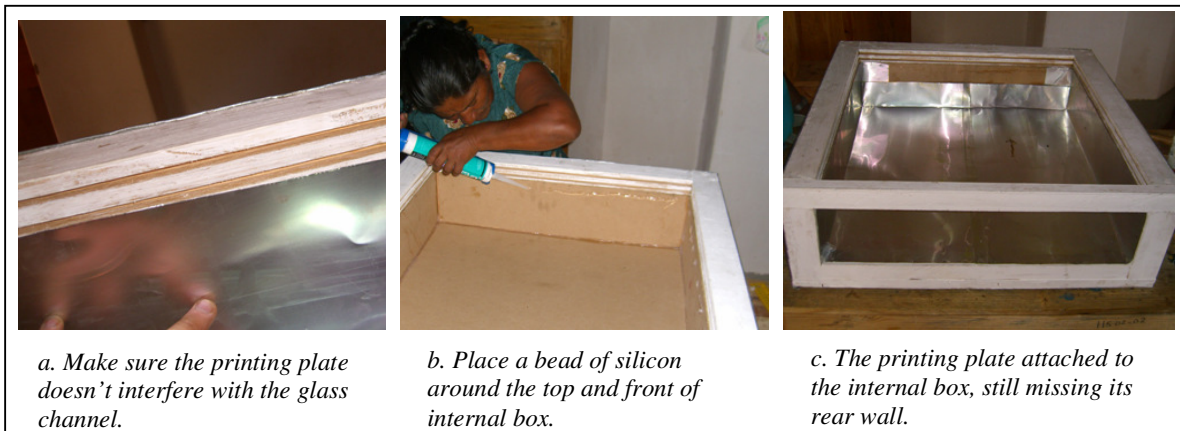

- xxiv) Measure the height and width of the back wall and cut a piece of printing plate metal to fit, overlapping the pieces that are already there.
- xxv) Put silicon sparingly over the entire area of the back wall of the internal box to stick the back on.
- xxvi) Nail the back in only across the top with 1" nails, making sure none of the nails protrude into the glass channel.

Internal Box

- xxvii) Lay the cooker on its back and place some heavy rocks or bricks on top of the rear wall for 15 minutes to allow the silicon to dry.
- c) Paint the metal sides of the cooker
 - i) Take the cooker outside and paint the sheet metal sides with marine blue paint.
 - ii) The paint should be mixed with paint thinner at a ratio of 80% paint to 20% paint thinner.
 - iii) It will require two coats, so leave it in the sun to dry faster. Make sure the first coat of paint is fully dry before doing the second coat.
 - iv) Be careful not to get paint on the white wood. You can decorate the top of the white wood of the glass frame however you like.

6) Reflector

- a) Assemble the reflector frame
 - i) Assemble the reflector frame in the same way that you assembled the frame of the base of the cooker. Use the 4 pieces that are 31" long. Remember to put glue into the lap joints and keep the frame square. It doesn't need to be perfectly flat like the base so there is no need to use the planer.
 - ii) Flip the reflector frame over so the points of the nails face upward.
 - iii) Use a hammer to bend over any points that may be sticking out of this side. Be sure that you are bending over the nail points rather than just pushing the nails back out the other side.
- b) Attach the sheet metal for the reflector
 - i) Cut a square of sheet metal that measures 31" x 31"
 - ii) Lay the square of sheet metal over the reflector frame and line it up as well as you can.
 - iii) Nail the 31" x 31" sheet metal to the reflector frame using 1" nails, 2" apart around the entire perimeter.
 - iv) Use a hammer to bend any over hanging metal around the edges of the reflector frame.
- c) Make the reflector lid
 - i) Cut another square of sheet metal that measures 36" x 36"
 - ii) Measure and mark 1" in from the edge on all sides.
 - iii) Lay the sheet metal on a work table and line up one of the marks with the straight edge of the table
 - iv) Bend the sheet metal over the edge of the table using a hammer, use the edge of the table as a guide, starting at one end and working your way across the sheet metal.
 - v) Flip the sheet metal over and carefully use your hands (with gloves!) to fold it over further. If it is too hard, start it off at one edge with the hammer or use pliers.
 - vi) Use a hammer to finish flattening the fold down. Be careful not to hammer too much because the metal may break.
 - vii) Repeat the folding process for the remaining 3 sides.
 - viii) Flip the reflector lid over so the folds are on the bottom

Figure 18



- ix) Measure and mark each corner 1" x 1" to make a chamfer on each corner.
- x) Line up the mark with the edge of the table and hammer the corner over the edge of the table.

Reflector

- x) Flip the reflector lid over and bend the corner over farther using large pliers. Grip the corner such that the end of the pliers is on the line where you want to fold. This will ensure that it folds where you want.
 - xii) Use a hammer to finish the fold and make it flat.
 - xiii) Flip the reflector frame over so that the side without any sheet metal is facing upward
 - xiv) Lay the reflector top that you just prepared over the reflector frame.
 - xv) Center the reflector top on the frame.
 - xvi) **Choose which side will be the back and then move the sheet metal forward so that that the two rear corners are just barely covered by the sheet metal.**
 - xvii) Screw the top onto the reflector using 1" screws four inches apart. You will need to puncture holes in the sheet metal using a nail. When punching holes make sure that you are in the center of the wood area and not outside or you will leave an ugly hole in the lid.
- d) Paint the reflector
- i) Take the reflector outside and paint the top and four sides only, don't paint the bottom side where the 31" x 31" sheet metal is nailed on.
 - ii) The paint should be mixed with paint thinner at a ratio of 80% paint to 20% paint thinner.
 - iii) It will require two coats, so leave it in the sun to dry faster. Make sure the first coat of paint is fully dry before doing the second coat.

7) Door

- a) Measure the correct size and cut out the door.
 - i) Attach the front piece of the glass frame to the cooker. Use one 3" screw in each side. Make sure you tighten it gently so the wood doesn't crack, but also make sure the screw is completely driven in so that the surface is flat. The screws should be put in the center of the rule, where there is material between the two channels and close to the edges of the rule where it won't interfere with the glass.
 - ii) Measure the front of the cooker frame, height and width.
 - iii) **Subtract ¼" from the height and ADD ¼" to the width and cut a piece of ½" thick plywood to these dimensions.** The door dimensions should come out to about 30 ¼" x 10 ¾". (We subtract ¼" from the height because if the door is too tall it will interfere with the reflector when it is closed; we add ¼" to the width to allow for a little extra room so we can make sure the door is flush with both sides of the cooker when it is attached. We need it to be flush with both sides so that the latches will work correctly. (There may be some need to plane down the width of the door later, but that will be done after it is attached to the cooker.)
- b) Make the inner door box
 - i) Place the plywood door over the front of the cooker and **make sure it is centered from side to side and flush with the bottom of the cooker.**
 - ii) Carefully trace the opening of the door way on to the plywood. **Use an arrow to mark which side is the top.**

Figure 19

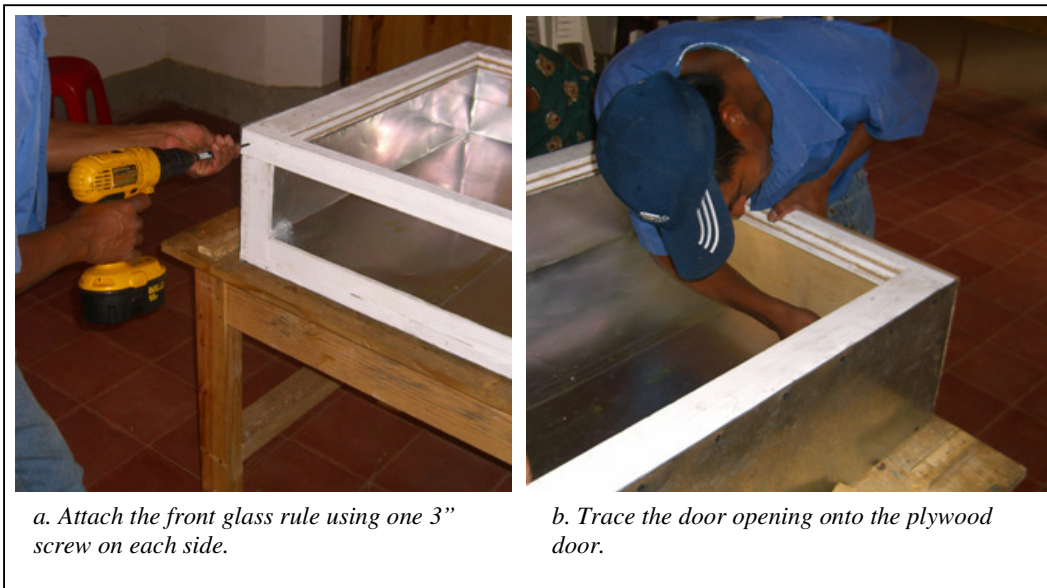

- iii) Measure the height of the door opening on the cooker frame, it should be about 6 ¼"
- iv) Cut 3 wood support blocks out of wood that is 1" thick by 2" wide. The height of each support block should be equal to the height of the door opening minus ½". (about 5 ¾")
 - (1) Cut each block into a trapezoid shape as indicated in Drawing 12.
 - (2) **Make sure all three are exactly the same height.**
- v) Place the three wood support blocks onto the plywood door inside the trace of the door opening. Put one just inside each side line (about 1/8" in from the edge) and

Door

one in the middle. Center all of them from top to bottom. **Make sure the angled side is pointed at the top of the door.**

- vi) Trace each wood support block in its place and remove them
- vii) Measure and mark $1\frac{1}{2}$ " down from the top of each traced rectangle of the wood support blocks and $\frac{1}{2}$ " up from the bottom of each one. Make your marks in the center of each rectangle from side to side.
- viii) Drill a $\frac{1}{8}$ " hole at each mark to indicate where the screws will go.
- ix) Glue each wood support block into its place over the traced outline. Let them dry for 10-15 minutes.
- x) Flip the plywood door over carefully and drive two $1\frac{1}{2}$ " screws into each wood support block from the front of the plywood door, using the holes previously drilled. Be careful not to shift or move any of the wood support blocks, they must be in their exact places or the door won't fit properly.

Drawing 12 – Wood support block for the door

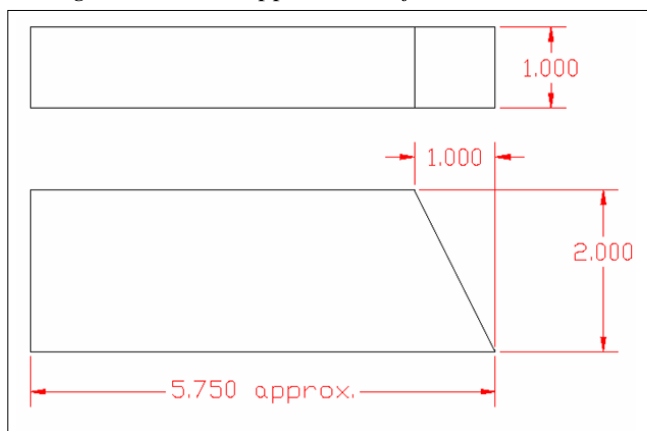
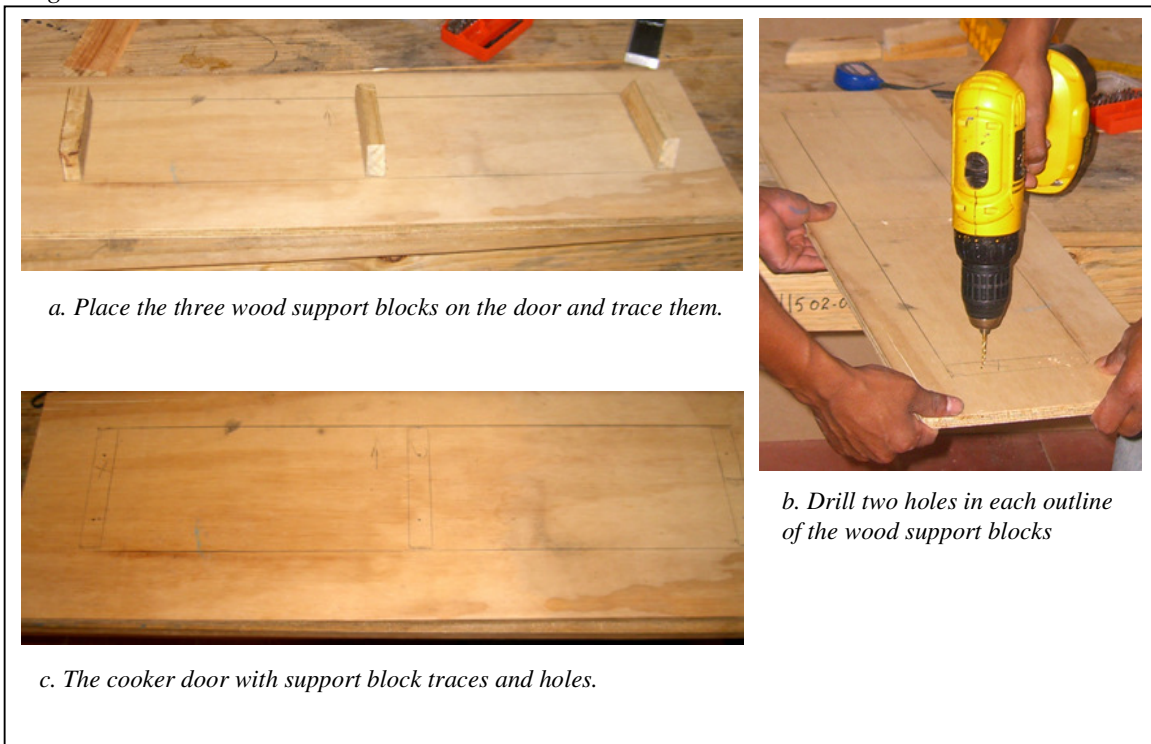

Figure 20



Door

- xii) Measure the width from the outside edge of the left most block to the outside edge of the right most block.
- xiii) Cut a piece of fiber board for the bottom of the inner door box that is $\frac{1}{4}$ " less than the width measured by $1\frac{7}{8}$ " high.
- xiv) Nail the bottom of the inner door box to the flat side of wood support blocks using 1" nails. Drive two nails into each block, one at the middle and one at the base of each block. You will need to leave space at the top for another nail later on.
- xv) Cut another piece of fiber board to the same width as the previous piece and a height of $2\frac{1}{8}$ ".
- xvi) Nail the top of the inner door box to the wood support blocks. Drive two nails into each block, one at the middle and one at the base of each block. Again, you will need to leave space at the top for another nail later on.
- xvii) Test fit the door onto the cooker again and make adjustments as necessary.
- xviii) Use the silicon gun to place a small bead of silicon around the inside perimeter of the inner door box. This will seal the box, helping it to insulate.
- xix) Cut a piece of printing plate sheet metal to the same length as the two fiber board pieces and a width equal to the size of the opening on the front of the inner door box plus $1\frac{1}{4}$ ".
- xx) Lay the metal onto the front of the inner door box and make sure it is straight and centered. Bend the edges over both sides where there is fiber board, making a crease at the four corners of the box.
- xxi) Take the sheet metal off and use the creases as a guide to fold it over the edge of the table to 90° .
- xxii) Test fit the printing plate metal again to make sure it is straight and fits properly.
- xxiii) Remove the metal and fill the door box with insulation
- xxiv) Place a small bead of silicon around the perimeter of the opening in the inner door box
- xxv) Place the printing plate metal over the opening and nail it into place with 1" nails. Use 3 nails across the front of each wood block and one nail in each side.

Figure 21

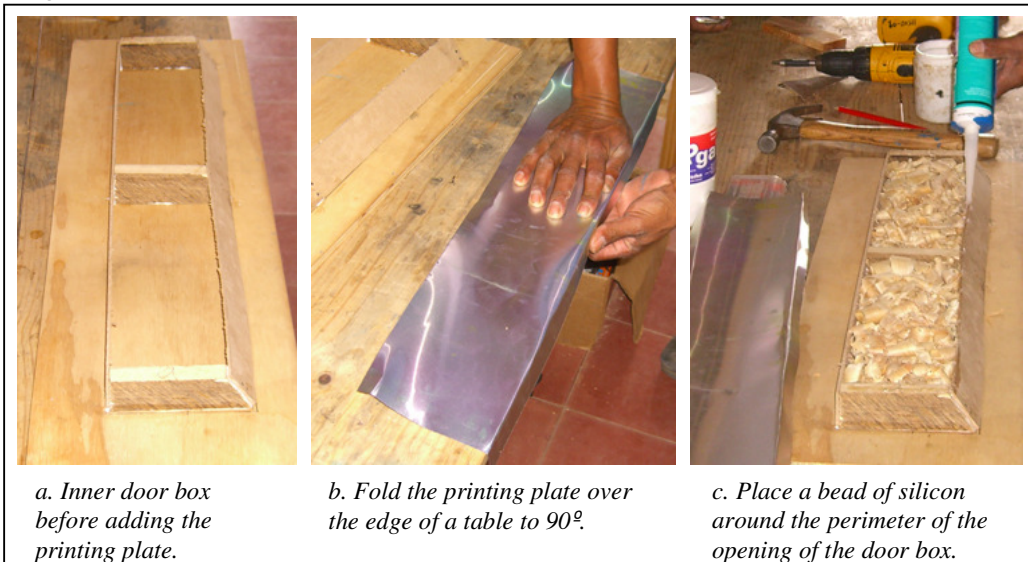

Door

- c) Attach the door hinges.
- i) Measure and mark 6" in from each side of the door on the same side as the inner door box.
 - ii) Place two 3" hinges on the door so that they are both just inside the marks.
 - iii) Trace the hinges in place
 - iv) Use a chisel to cut out the rectangular area of the traced hinge. Cut it 1/16" deep, the thickness of the hinge.
 - v) Screw each hinge into its recessed area with 1/2" screws, 3 for each hinge. If there are no 1/2" screws available use the shortest screw you can find and cut off the point that protrudes through the front of the door with a hacksaw.
 - vi) File down the points of the 6 screws that poke through the other side of the door with a metal file.

Figure 22

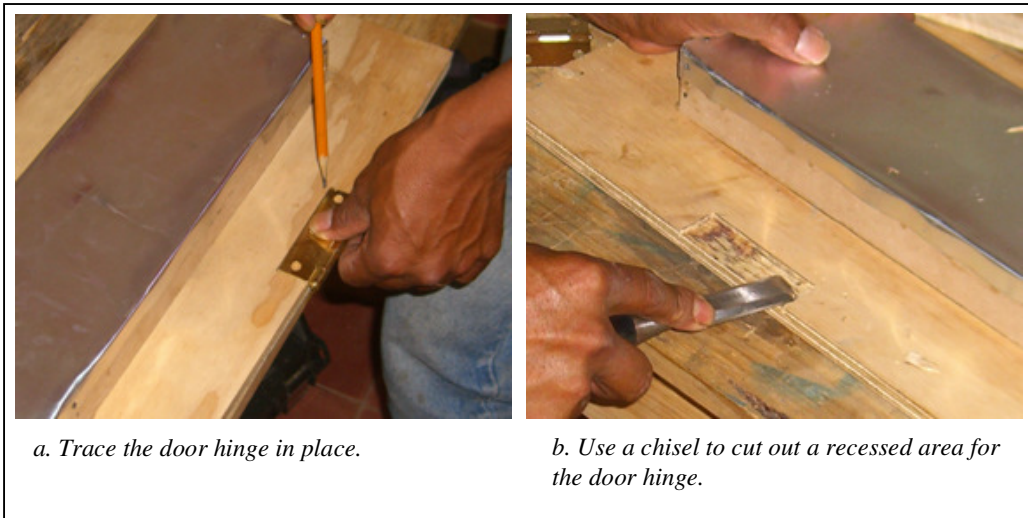

- d) Attach the door to the cooker
- i) Lay the cooker on its back side so that the door opening is facing upward.
 - ii) Fit the door into the front opening making sure that it is centered from side to side and flush with the bottom of the cooker.
 - iii) Screw in the hinges.
 - (1) Make sure the hinges lay over the bottom side of the cooker.
 - (2) Use a nail to puncture the sheet metal in the center hole of the hinge and then drive in a 1 1/2" screw. There should be 3 screws for each hinge.
 - (3) Screw in only the middle screw on each hinge first, and then check the door to make sure it opens and closes properly.
 - (4) Test the door fit by closing and opening it.
 - (5) Add the last two screws to each hinge
 - (a) **Make sure that the door is flush with both sides of the cooker** because it has to be flat to attach the latches properly. If the door is too big on one side you can use the planer or file or sand paper to flatten the door down to the width of the cooker. Remember we made the door 1/4" larger than the cooker to allow for room to plane here. If the door is too small on one side you may need to add some material to the side to make it flat for the latches. A strip of fiber board or cardboard works well.
 - (b) Check the door fit again, if the door extends past the height of the front glass piece you will need to use a planer to plane it down. Otherwise, it will

Door

interfere with the reflector. The door should be about 1/8" below the top of the front glass piece.

- e) Attach the sheet metal to the front of the door
 - i) Cut a piece of sheet metal to perfectly match the size of your door after you have attached the door to the cooker and made any needed adjustments with the planer/file. (it should be about 10 3/4" x 30")
 - (1) Round off the corners of the metal piece before screwing it to the door, cut a very small curve into the corner to take off the sharp point using the tin snips
 - ii) Place the sheet metal over the door, be careful to center it and leave no sharp edges hanging off.

Figure 23

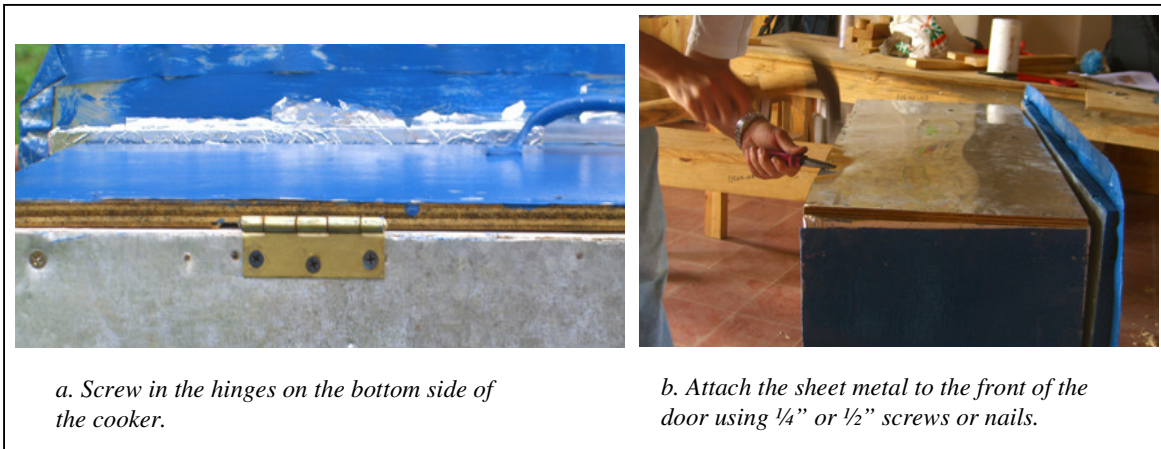

- iii) Use 1/4" or 1/2" screws across the top and bottom, spaced 5" apart. On the sides only 3 screws are needed, at the top middle and bottom. Use a hammer and a nail to puncture the metal before driving in the screws.
 - (1) As you are adding screws make sure to maintain the sheet metal flat and start at one end of the door adding screws to both the top and bottom sides equally working your way towards the other edge. This will prevent bubbles in the sheet metal.
 - (2) If no 1/4" or 1/2" screws are available you can cut 1" nails down to size and use them. These nails will be very short and you will need to use some needle nose pliers to hold the nail while driving it in.
- iv) Use a hammer and bend over any part of the sheet metal on the door that is hanging over the edge.
- f) Paint the door
 - i) Take the cooker outside and paint the front and four sides of the door. Don't get paint on the hinges because it will make them stick.
 - ii) The paint should be mixed with paint thinner at a ratio of 80% paint to 20% paint thinner.
 - iii) It will require two coats, so leave it in the sun to dry faster. Make sure the first coat of paint is fully dry before doing the second coat.
 - iv) Also paint two coats on the door handle before it is attached to the door. The handles tend to rust quickly and it is best if all sides of the handle are painted rather than just the front.

8) Black Collector Plate

- a) Cut a piece of sheet metal to 24.5" x 25.5"
- b) Measure and mark 1" in from each side, except for the front. The sides measure 25.5" and the front and back measure 24.5". (See Drawing 13)
- c) Cut 1" in along the line on each of the two sides starting from the back and going forward until you reach the 1" line along the back side. Your cuts should only be 1" long on each side. (See Drawing 13)

Drawing 13 — Black collector plate

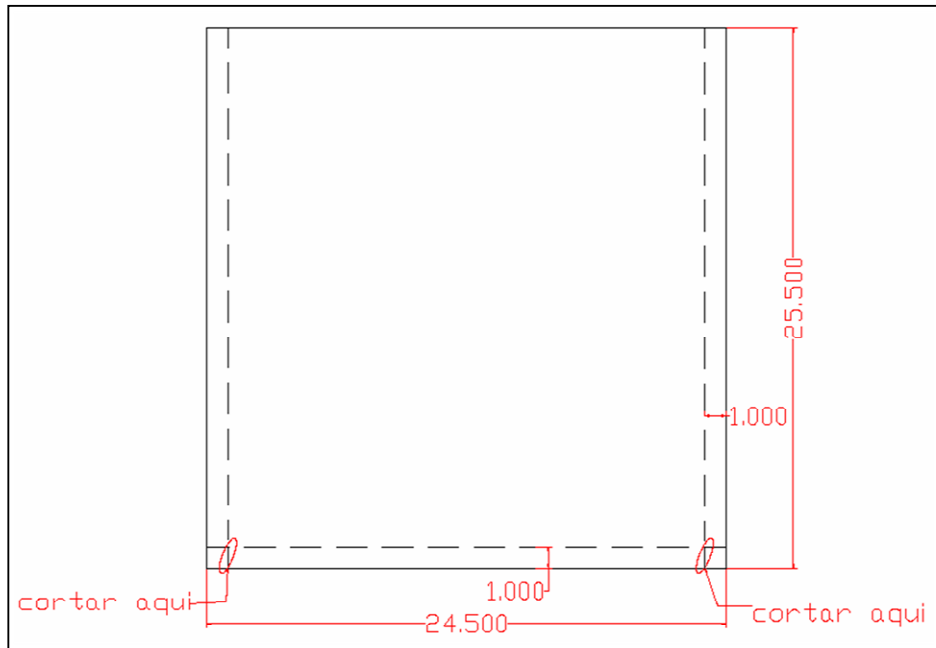

- d) Fold all 3 sides up to 90 degree angles, leaving the front flat.
- e) Fold the two tabs in at each corner
- f) Use a 3" nail to punch a hole through the tab and the collector plate wall in each corner so that a rivet can be put in.
- g) Place a rivet in each hole and use the rivet gun to fasten them.

Figure 24



a. Bend the edges of the collector plate over the edge of a table with a hammer.

b. Use a rivet to fasten the corners of the collector plate together.

c. The corner of a finished collector plate, before painting.

Black Collector Plate

- h) Round off the two front corners of the collector plate with tin snips so there aren't any sharp edges.
- i) Attach the five wood insulation blocks to the bottom
 - i) Put one $\frac{1}{2}$ " x 2" x 2" block in each corner and one in the middle. Spread white glue over each one to stick it into place.
 - ii) Let the glue dry for 10-15 minutes
 - iii) Flip the collector plate and use two $\frac{1}{2}$ " black screws in each block screwing in from the top through the collector plate.
 - (1) If no $\frac{1}{2}$ " screws are available use the shortest screw you can find and use a hacksaw to cut off any points that poke through the wood blocks, then a metal file to smooth the rough point.
 - iv) Paint the top side of the collector plate with black anticorrosive paint. Use two coats if necessary.

Figure 25



9) Assembly and Finishing

- a) Attach the door latches
 - i) The door latches will go on the sides of the cooker. The hook will be attached to the side of the door and the latch gets attached to the cooker.
 - ii) **Make sure to place them below the front glass piece.** This piece needs to remain easy to remove for replacing broken glass or cleaning the glass.
 - iii) Verify that each side of the door is flush with the side of the cooker before attaching the latches. If the door is too small you may need to put a piece of cardboard or fiber board beneath the hook before attaching it to the door.
 - iv) Attach the hook to the door first; making sure it is facing the correct direction. Use 1" screws; a screw driver is recommended instead of the drill because the side of the plywood is very soft and you don't want to over tighten.
 - v) Attach the latch to the side of the cooker
 - (1) Line up the latch on the side of the cooker and engage the hook completely, still holding it on the side with your hand. Mark the hole locations, then remove the latch.
 - (2) Make a new mark on the side of the cooker 1/16" behind the latch markings; this will allow the latch to be tight.
 - (3) Use a nail to puncture a hole in the sheet metal where the new mark first screw is.
 - vi) Replace the latch holding it to the side of the cooker so it matches the puncture and drive in a 1" screw.
 - vii) Test the latch to see that it lines up with the hook and engages properly. (It is difficult to judge the tightness with one screw missing, but it will still give you an idea if it is too tight or too loose)
 - viii) Make sure the latch is lined up vertically so that it is straight and use a nail to puncture a hole at the second screw location.
 - ix) Drive a 1" in screw at the second mounting hole.
 - x) Test the latch again to make sure it works correctly.
 - xi) Repeat for the second latch.

Figure 26

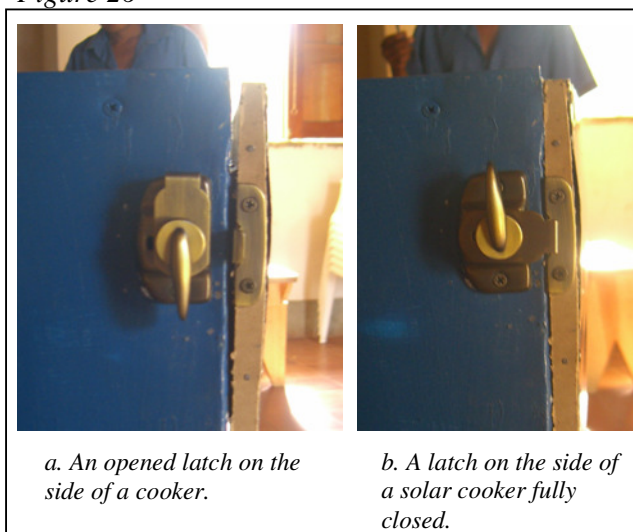

a. An opened latch on the side of a cooker.

b. A latch on the side of a solar cooker fully closed.

Assembly and Finishing

- b) Attach the reflector to the cooker.
- i) Use 3.5" hinges to attach the reflector to the cooker
 - ii) Measure and mark 4 ½" in from each side on the back of the reflector; which is the side that has the least amount of metal overhanging from the lid.
 - iii) Hold the hinge up to the back of the reflector with the outside edge lined up with the 4 ½" marks and so that the tops of the hinges are flush with the metal lid.
 - iv) Drive in three 1 ½" screws into each hinge to attach them to the reflector.
 - v) Lay the reflector on top of the cooker centered from side to side and flush with the back and so that the hinges lay outside the cooker against the back wall. (See Figure 27)
 - vi) Mark all three screw holes for the hinges on the back of the cooker. If there is a screw in the way from attaching the sheet metal sides remove it.
 - vii) Verify that the reflector is laid flat on top of the cooker and centered from side to side, flush with the back.
 - viii) Use a nail to puncture the sheet metal and drive in a 1 ½" screw through the center hole of the hinge.
 - ix) Repeat for the second hinge, only attaching the center hole on the bottom of the hinge. Make sure the screws are tight.
 - x) Test the reflector by opening and closing it a couple times gently, making sure that you don't stress the hinge since there is only one screw attached. If the reflector is not straight, flat, or centered you will need to make adjustments.
 - xi) If you are happy with the reflector placement finish screwing in the hinges on both sides.

Figure 27



a. Use a nail to puncture the sheet metal before screwing in.



b. Screw in the hinges using 1 ½" screws.



c. Reflector attached to the solar cooker, showing the hinge locations.

Assembly and Finishing

- c) Glue aluminum foil to the reflector
- i) Open the reflector and lean it against a wall so that it is angled backwards.
 - ii) Prepare a mixture of glue and water with 20% water 80% glue; just enough water to make the glue liquid enough to paint.
 - iii) Use a paint brush and paint on the glue mixture over the entire metal reflector surface.
 - iv) Take a roll of aluminum foil in one hand, unroll it a few inches and lay the edge at the top of the reflector. Make sure the shiny side faces out. Have a friend hold the edge in place at the top as you unroll the aluminum foil down the reflector. Move slowly making sure you keep the foil straight. Have your partner follow behind the roll with a soft cloth smoothing the foil down and pushing out bubbles as it is laid onto the reflector. Try your best not to make wrinkles in the foil because this reduces the reflectivity.
 - v) When you reach the bottom use a sharp utility knife to cut the foil even with the bottom of the reflector.
 - vi) Use the paint brush to paint a 1 ½” wide line of glue down the inside edge of the foil stripe you just laid so that the next stripe will stick to the overlapped portion.
 - vii) Begin from the top again with the foil roll and run down the reflector making sure that you maintain the foil straight and overlapped with the previous pass by about 1 ½”.
 - viii) It should take 3 passes with the aluminum foil to cover the reflector. When finished, trim excess foil at the top and sides with the utility knife.
 - ix) Close the cooker and allow the glue to dry for 30 min.

Figure 28



- d) Drill and Attach the reflector prop rods
- i) Drill holes in the reflector prop rods that will be used for adjusting the reflector angle
 - (1) Start on one end, ½” in from the end and centered. Make a hole with a ¼” drill bit.
 - (2) Make 9 more holes starting 1” away from the first hole and 1” apart and centered on the prop rod.
 - (3) When drilling the holes set the drill on its highest speed and use very little pressure to make the hole to avoid splintering the wood as the drill bit reaches the other side.
 - (4) Run the drill bit through each hole a few times to make sure it is well drilled.

Assembly and Finishing

- (5) Make one more hole for mounting the prop rod to the reflector
 - (a) Measure $\frac{3}{4}$ " from the top of the prop rod and $1 \frac{3}{8}$ " in from one side, mark and drill at this location with the $\frac{1}{4}$ " drill bit.
 - ii) Take two 3" nails and crush the heads by hammering it on a hard surface, such as a rock or an anvil. The nail heads should easily pass through the $\frac{1}{4}$ " holes made in the prop rods. If they don't pass through easily, you either need to re-drill the holes or hammer the nail head more. Do not make the holes bigger than $\frac{1}{4}$ " or they will be too big and the prop rods will slide off the nails in the wind, causing damage to the cooker.
 - iii) Locate the column in the center of each side of the cooker and make a mark in the middle of it 2" down from the top of the cooker wall.
 - iv) Use the nails that have the crushed heads and nail one into each side at the mark, only 1" deep so that 2" of nail is still sticking out.
 - v) Open the reflector and mark 10.5" down from the top on each side.
 - vi) Hook the last hole of the prop rod onto the nail in the side of the cooker.
 - vii) Line up the hole in the top of the prop rod with the mark on the reflector so that the off-center hole is closer to the metal top of the reflector and drive a 3" nail through the hole into the side of the reflector. Don't nail it in all the way, leave about $\frac{1}{4}$ " space so that they prop rod has some flexibility to move.
 - viii) Repeat for the second prop rod.
- e) Attach the mirror to the reflector
 - i) Measure and mark the center of the reflector on the very top edge of the reflector
 - ii) Spread white glue generously all over the back of the 2" x 4" mirror.
 - iii) Stick the mirror to the very top of the reflector centered over the mark in the middle.
 - iv) Carefully close the reflector with a piece of folded up cardboard beneath the mirror and allow the glue to dry over night.
- f) Attach the door handle
 - i) Find the center of the door using a tape measure across the top of the cooker door.
 - ii) Measure one inch down from the top of the door, centered from left to right
 - iii) Place the door handle centered over the spot you located and mark the hole locations
 - iv) Use a nail to puncture the sheet metal at each hole and drive a $\frac{1}{2}$ " screw in each hole.
 - v) Open the door and file off any screw points that passed through the door.

Figure 29

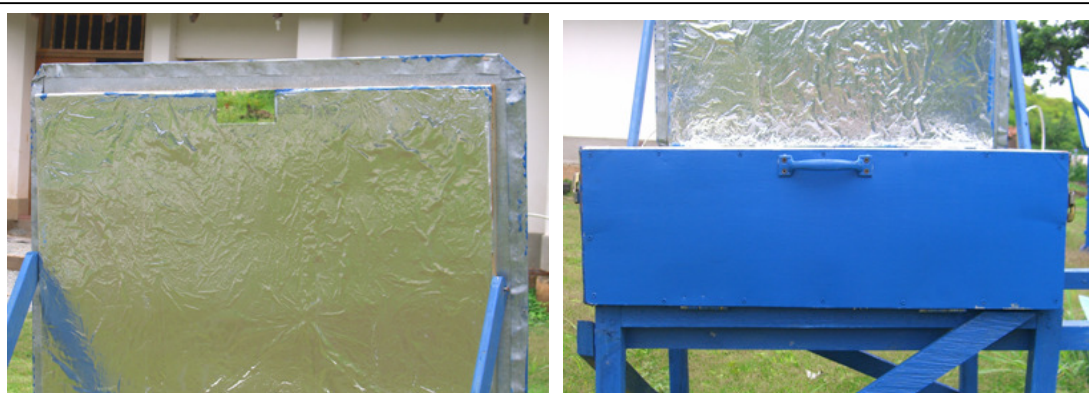

a. Glue the mirror to the top-center of the reflector.

b. Attach the door handle to the top-center of the door front.

Assembly and Finishing

- g) Make the door seal
 - i) Cut the handles and bottom out of a plastic grocery bag, and slit it down one side so that you have a large flat sheet of plastic
 - ii) Use a sharp utility knife and a straight edge to cut 3” wide strips of plastic the full length of the sheet.
 - iii) Cut the point for a tube of silicon off so that it leaves a very large hole so that the silicon comes out as a thick bead.
 - iv) Open the door of the cooker and have someone hold it flat for you, parallel to the ground.
 - v) Put down a thick bead of silicon around the perimeter of the inner door box with a space of about one inch between the inner door box and the bead of silicon.

Figure 30

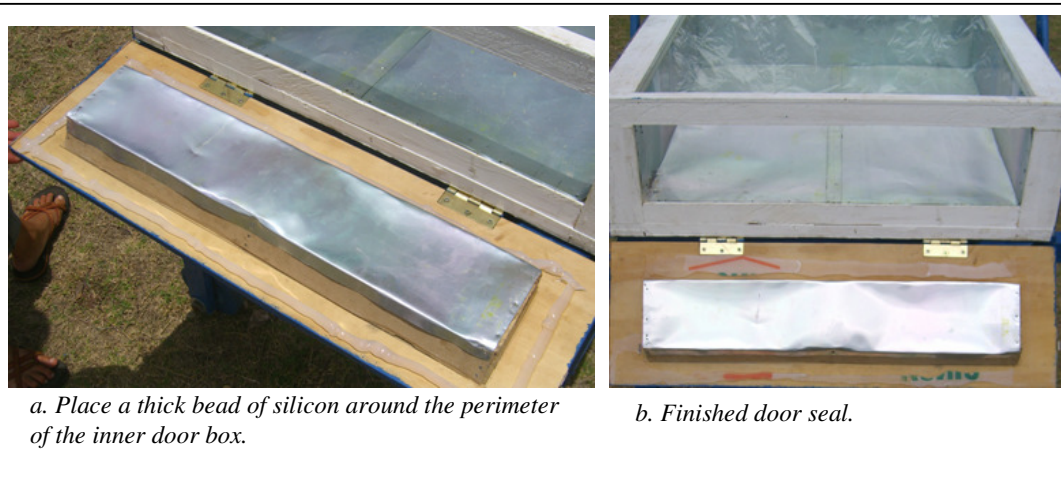

- vi) Lay the strips of plastic over the beads of silicon; just touching the plastic to the silicon. **Be careful not to squish the silicon bead at all.**
- vii) Gently close the door without putting any pressure on the wet silicon, close it just enough to let the latches shut completely. This will allow the silicon to naturally fill any spaces between the door and the cooker.
- viii) Close the lid and leave the silicon to dry overnight. If the reflector is left open, the cooker will heat up and possibly melt the plastic onto the silicon, preventing you from peeling off the plastic later.
- ix) Open the door carefully, using a utility knife to cut away silicon that oozed out of the door. If the strips of plastic were wide enough this should be easy, but if any silicon has spread past the plastic strips it will glue the door shut. Be careful to make sure that as the door is peeled back you try to keep the silicon stuck to the door side.
- x) Gently remove the plastic strips and cut away any excess silicon that has oozed out of the cooker. If any part of the plastic strips will not come off easily it is ok to leave it. Just cut away the excess plastic and make sure you don't peel off the new silicon seal.

10) Conditioning the Solar Cooker

- a) The first time a solar cooker is heated up it needs to be done carefully to allow the glass and wood to expand slowly so that the glass doesn't break.
- b) Open the cooker door and remove the black collector plate.
- c) Leave the door open and open the reflector to the correct angle and turn the cooker towards to the sun.
- d) Allow the cooker to heat up to its maximum possible temperature with the door open and no black collector plate.
- e) Place the black collector plate inside the cooker leaving the door open.
- f) Allow it to reach its maximum temperature with the collector plate inside and the door open.
- g) Close the cooker door and allow the cooker to get to its maximum temperature again. This process will help minimized the frequency of glass breaking on new cookers the first time they get hot.